

Special inspection to increase the TBO for engine

Mandatory

- Subject:** Increase of TBO from 600^h/10 years to 1000^h/10 years.
- Engines affected:** Generally all engines of Series Type 912 A up to and including engine N. 4,380.693 in accordance with Type Certificate TW 8/89, with the exception of V912/1983, V912/1920, 3,792.605, 3,792.701, 3,792.788, 3,792.789, 3,792.790, 4,005.013, 4,005.083, 4,005.133. From engine N. 4,076.192 onwards the 1000^h TBO is covered by TM 912-04.
- Reason:** In the agreement of the 27, July 1992 with the Type Certificate Authority ACG the program for the 1. extension of the time between overhauls was conducted. Owing to the good findings of the 5 engines examined the TBO can be increased from the present 600^h/10 years to the period of 1000^h/10 years.
- || Engines with N. 4,076.192 to 4,380.693 have been added, due to TBO extension to 1200 hours.
- Compliance:** On all engines up to and including engine N. 4,076.191 the 600^h examination has to be carried out to obtain the TBO of 1000^h/10 years.
- Remedy:** Not applicable.
- Accomplishment:** The 600^h inspection to be performed according to instructions overleaf. Amendment N. 4 of the Operator's Manual in May 1994 to be entered without delay or the Manual to be exchanged for a new one of Series 912 A - Rev. 4
- The necessary measures to be taken and confirmed by the producer or by persons entitled from the Aviation Authorities. New Operator's Manual with the amendment N. 4 from May 1994 entered, is readily available at Bombardier-ROTAX, A-4623 Gunskirchen.
- Approval:** The technical contents of this Technical Bulletin have been approved by ACG on 29th of July 1996.

Gunskirchen, 1996 07 19

Instructions:

1) Basically:

On the occasion of the 600h inspection the following tasks as per state of amendments have to be taken care of. As guideline use amendments list under consideration of the existing Technical Bulletins.

1.1) Technical Bulletins

The following Technical Bulletins have to be taken into account TM 912-01, TM 912-02 rev. 1, TM 912-04

1.2) State of amendments:

The following modifications as per list of amendments have to be carried out.

Amendment no.	Concerning	up to and including engine N.
15	Introduction of friction washer at drive gear	3,792.880
17	Length of oil pump rotor increased from 13 mm to 16 mm.	3,792.943
22	Conversion to modified compression spring in oil pump to improve pressure control.	4,005.185
28	Change to inside centering of disk springs in the gear box.	4,076.009
32-01	Oil tank of steel with a drain plug	4,076.023
32-17	Shim to adjust pressure of relief valve on oil pump.	4,076.098
32-19	Rubber plate for protection of expansion tank	May 1993
34	Change to steel bush in dog gear.	4,076.171
35-01	Three disk springs 3 mm thick instead of two with 3 mm and one with 2,5 mm thickness.	4,076.173
35-02	Washer in water pump out of stainless steel.	4,076.178
35-04	Thrust washer behind retaining ring in gear box out of wear resistant plastic.	4,076.191
35-10	Ring halves with hardness specification HV 10 600+100.	4,380.556
36-04	Step collar out of wear improved material.	4,380.649
36-10	Spacer out of wear improved material.	4,380.693

2) Withdrawal of propeller gear to attend amendments no. 28, 34, 35-01, 35-04, and 35-05.

Withdrawal of the gear box; in most cases with the engine installed in the aircraft. Disconnect minus terminal of battery. Remove engine cowling as required and propeller as per instructions of aircraft producer.

Remove the two Allen screws M8x45 and eight Allen screws M6x45 along with lock washers. The gear cover is positioned by two dowel pins. Fit the puller assembly ①, part no. 877 660, on the two tapped lugs M8 ② of gear cover. Tap off gear cover assembly by impact handle ③ without the risk of damaging propeller shaft and bearing. Clean sealing face of crankcase.

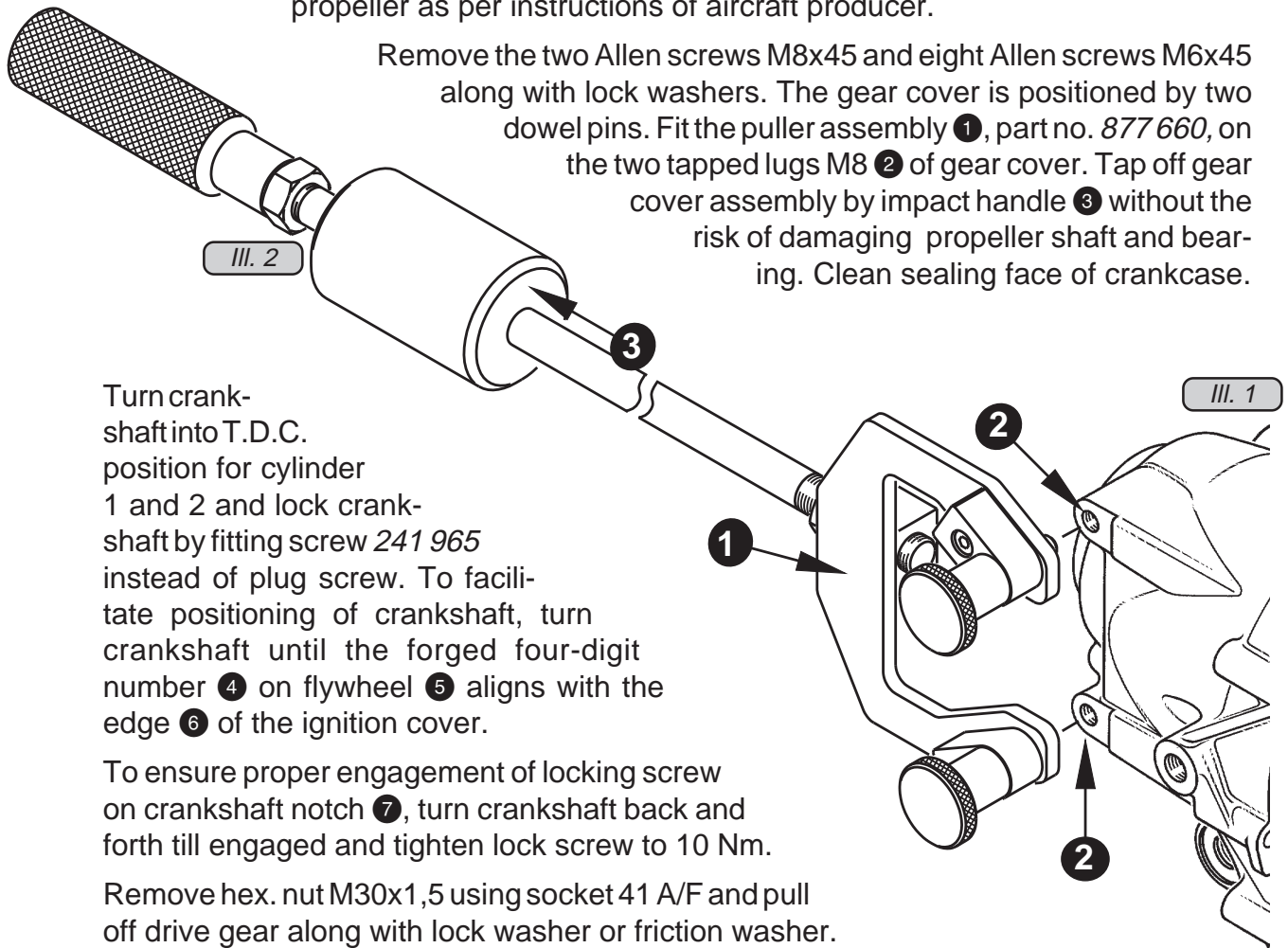

Turn crankshaft into T.D.C. position for cylinder 1 and 2 and lock crankshaft by fitting screw 241 965 instead of plug screw. To facilitate positioning of crankshaft, turn crankshaft until the forged four-digit number ④ on flywheel ⑤ aligns with the edge ⑥ of the ignition cover.

To ensure proper engagement of locking screw on crankshaft notch ⑦, turn crankshaft back and forth till engaged and tighten lock screw to 10 Nm.

Remove hex. nut M30x1,5 using socket 41 A/F and pull off drive gear along with lock washer or friction washer. If need be, facilitate with two screw drivers.

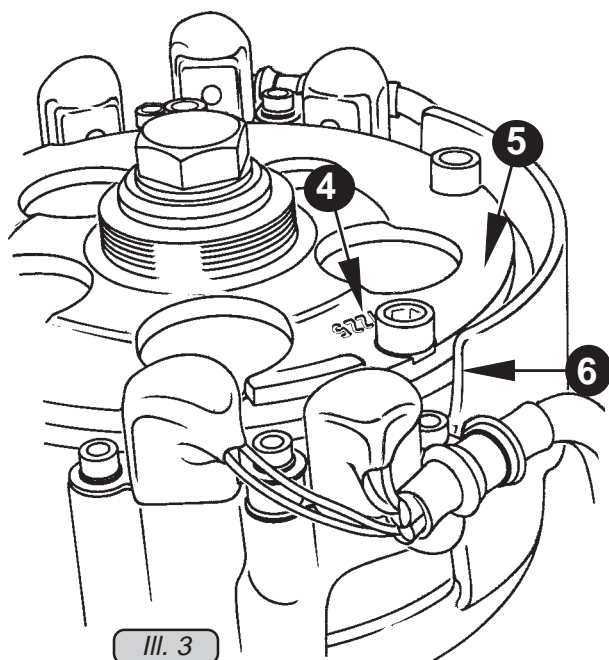

◆ NOTE: Hex. nut with left-hand thread.

Ensure that both dowel pins stay in the crankcase and not in the gear cover.

Send drive gear together with gearbox assembly to an authorized distributor or Service-Centre and request an exchange gearbox.

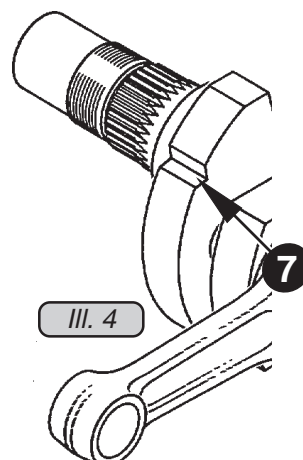

2.1) Friction washer, amendment no. 15:

If hex. nut is still secured by a lock washer, it has to be exchanged for the friction washer ①. Slide drive gear of the exchange gearbox on cleaned serration of crankshaft and fit friction washer and hex. nut M30x1,5.

■ **ATTENTION:** Secure hex. nut with LOCTITE 221. Hex. nut with L.H. thread.

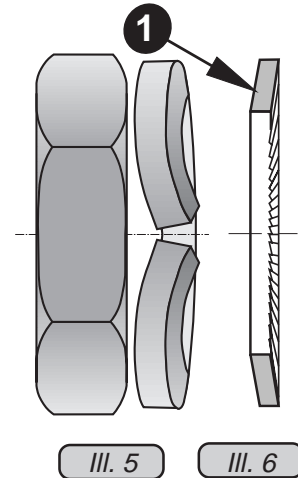

2.2) Renewal of oil seal and roller bearing on Type A1 and A2.

Remove circlip ① using a pair of circlip pliers. Attach puller structure ② 877 615 with 8 Allen screws M6x25 on crankcase. Fit stud ③ M10x45/20 into puller screw ④ 877 580 and hex. nut ⑤ M24x1,5 on puller screw.

For better guide push mushroom insert ⑥ 877 592 into roller bearing ⑦ and place puller screw into support ⑪ of puller. Place puller plate ⑧ 877 560 from backside of crankcase onto stud and secure with hex. nut M10 ⑨.

Hold puller screw at handle and turn hex. nut ⑤ clockwise until roller bearing along with oil seal ⑩ is pulled out of the housing. Remove the hex. nut ⑨ again, take off puller plate along with roller bearing and oil seal, withdraw puller screw and remove stud ③ from puller screw.

◆ **NOTE:** At this operation the oil seal will be damaged and has to be renewed.

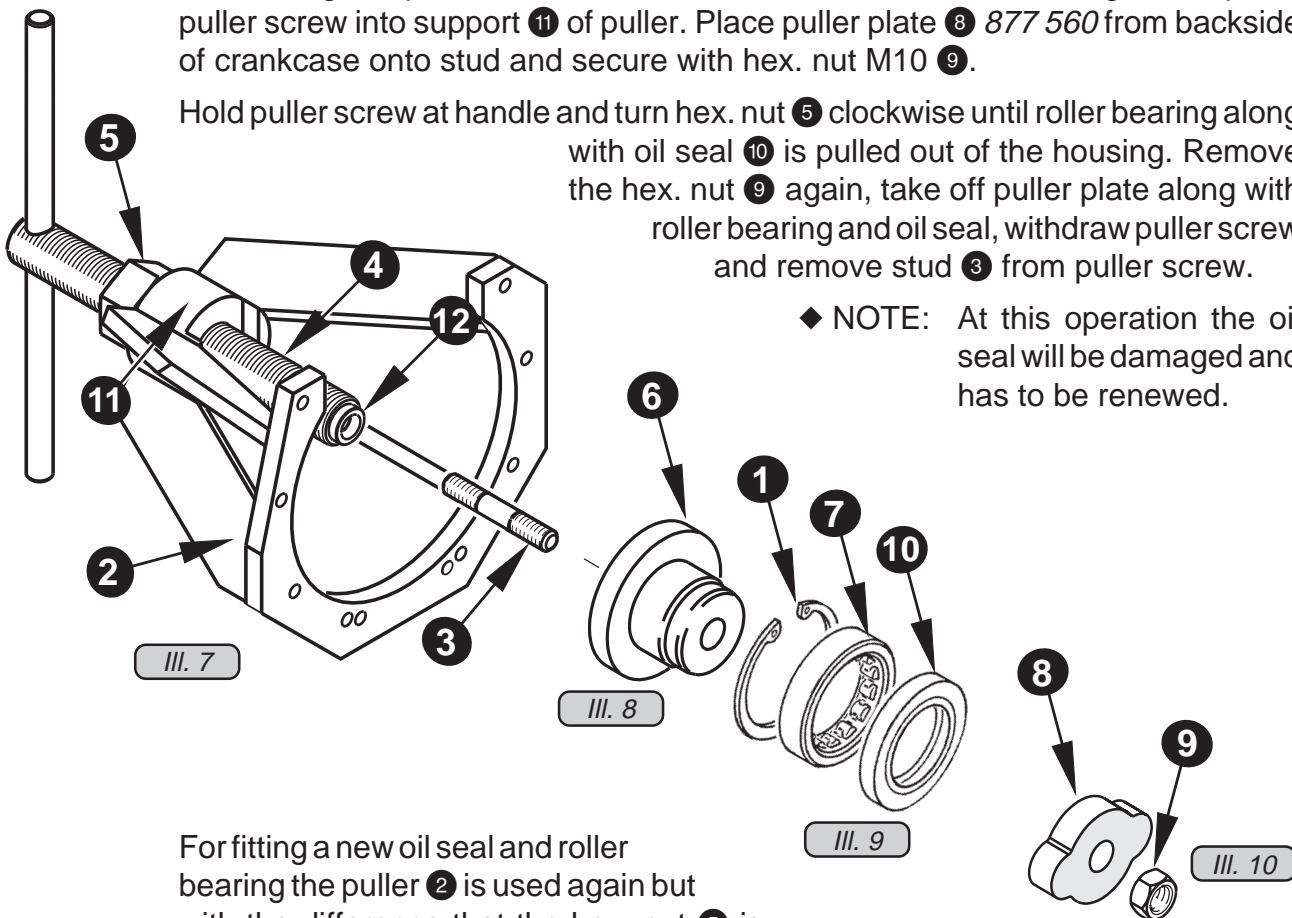

For fitting a new oil seal and roller bearing the puller ② is used again but with the difference that the hex. nut ⑤ is positioned in front of the support ⑪. Clean bearing seat. Place roller bearing and greased oil seal on mushroom insert ⑥ and put on centering ⑫ of puller screw. Press both items into position by turning puller screw clockwise. Fit circlip and grease roller bearing.

Remove puller assy from crankcase.

As on type 912 version A3 no oil seal is used on this location, only renewal of roller bearing at detection of pittings on bearing rollers is necessary.

2.3) Fitting of the exchange propeller gear:

Ensure that both dowel pins are on crankcase. Use grease to keep rollers of roller bearing in position. Apply sealing compound, LOCTITE 574 on clean sealing face of gear cover and put on pre-assembled prop gear.

■ **ATTENTION:** Put on gear cover parallel until engagement of the dowel pins and push on evenly on crankcase, using mallet if necessary.

Attach cover with two Allen screws M8x45 and eight Allen screws M6x45 along with lock washers and tighten screws to 25 Nm / 10 Nm. Check backlash of gears and fit and tighten cleaned magnetic drain plug to 25 Nm (225 in.lb.)

3) Oil pump amendment no. 17, 22 and 32-17:

Remove oil filter, using oil filter wrench. Take off oil pump along with 3 O-rings after removal of the 4 Allen screws M6x45 and lock washers.

◆ **NOTE:** Cut open oil filter and inspect filter element for foreign matter. This investigation reveals a lot about the condition of the engine.

Remove oil pump cover and inspect inside for wear. The gap between pump cover and rotor assy. must not be more than 0,2 mm (0,008 in.). A bigger gap reduces pump capacity greatly. Check sealing face of pump housing and pump cover. If need be, true on a ground plate. Remove rotary piston and rotor. Remove needle pin and withdraw pump shaft. At noticeable furrows on mating faces of rotary piston and rotor, renew both items.

Remove plug screw ① of pressure relief valve ②, clean valve and check ball seat in housing. Clear all oil passages by compressed air. From engine serial no. 4,005.186 onwards, to improve oil pressure control the following parameters of the relief valve were changed. Free length of the compression spring ③ was reduced from 46 mm to 39,5 mm. Spring rate was changed by increase of wire dia. from 0,8 mm to 0,9 mm, and dia. of ball was increased from 8 mm to 8,5 mm.

If existing, remove shim ④, but if specified oil pressure can't be reached, adjust pressure by adding shim again.

◆ **NOTE:** Starting with engine N. 3,792.944 the oil pump housing and oil pump cover is in pressure die cast. On this occasion capacity of the pump was increased by lengthening of the rotary piston assy. from 13 mm to 16 mm along with the respective changes of oil pump housing, pump shaft and O-rings.

From engine serial no. 4,076.068 onward the follower in the oil pump shaft ⑤ was changed to notched pin ⑥ instead of the former dowel tube.

At a renewal of components change oil pump to the version with the 16 mm long rotors.

Nominal oil pressure is 3,5 bar (51 p.s.i.) at 5800 r.p.m. and oil temp. of 110°C (230°F). Oil pressure above 5 bar (72,5 p.s.i.) is not permissible with engine at operating temperature. At idle speed oil pressure drops to 1,5 bar (22 p.s.i.).

Oil pressure has to rise within 10 seconds after engine start; If not find reason to prevent engine damage. At extreme low temperatures the oil pressure might rise up to 7 bar (100 p.s.i.) at engine start.

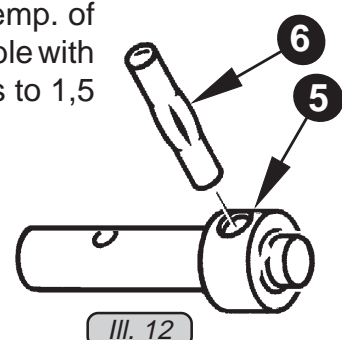
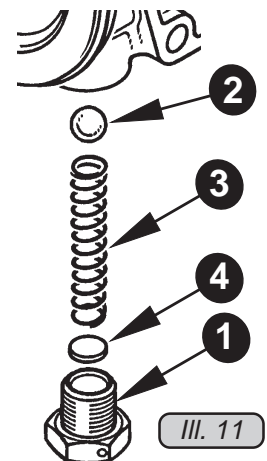

3.1) Oil tank, amendment no. 32-01

Starting with engine N. 4,076.024 on oil tank out of steel instead of aluminium is installed. On this occasion a drain plug was fitted too. Exchange aluminium tank for steel tank to comply with thermic specifications.

After the installation of the oil tank connect oil lines **correctly**, wire secure drain plug, fill up with engine oil according to specification in Manual and vent lubrication system.

3.2) Venting of the lubrication system

Fill oil supply line with oil. If the oil pressure does not rise within 10 sec. after engine start, then the engine must be stopped and the oil supply line for oil pump has to be vented as follows: First block oil return line by clamp and then connect compressed air (max. 3 bar = 44 p.s.i.) to venting line. Oil will be pushed from the oil tank to the oil pump within 30 sec. Remove clamp from oil return line and reconnect vent line.

4) Rubber plate, amendment no. 32-19

To prevent chafing of the expansion tank a protective rubber plate is glued to underside of expansion tank since May 1993. Inspect expansion tank and stick rubber plate to underside of tank.

5) Water pump, amendment no. 35-02

At engine operation without antifreeze in the coolant, increased formation of corrosion takes place. Therefore the material of the pump shaft was changed with engine serial no. 4,076.122. Because of galvanic reactions, caused by

the use of various materials, the washer ① and the screw ② are of stainless steel since engine serial no. 4,076.178.

The Allen screw ② extends into the waterspace and is therefore sealed by the gasket ring ③. After removal of the water pump housing, unscrew impeller ④ anticlockwise by use of the impeller wrench 877 295, with crankshaft locked.

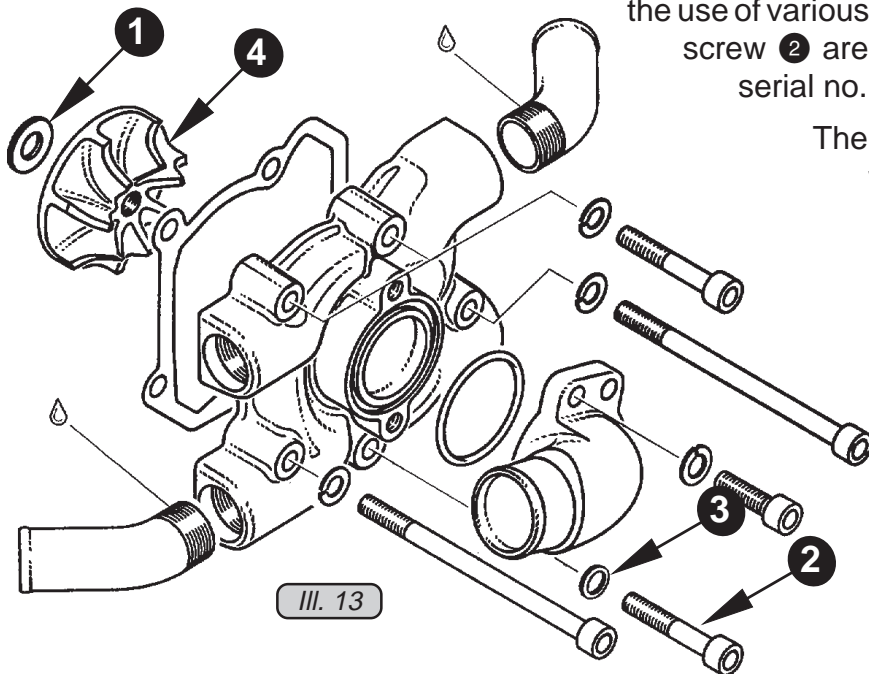

Check water pump shaft at runout of thread ⑤ for possibly existing corrosion. At bad corrosion renew water pump shaft. For this renewal remove ignition housing and fit new water pump shaft as per instructions in the Repair Manual.

Note: The new shaft can be recognised by a taper ⑥.

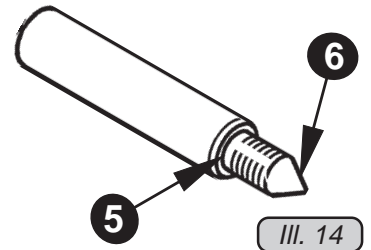

Ill. 14

6) Carburettor

Remove float chamber and lift out both floats. If float chamber is still without distance pieces ①, part no. 861 920, add them now, thus avoiding possible sticking of the floats in the float chamber.

Check support pin ② of floats. At heavy wear of float bracket contact faces, caused by excessive vibration, exchange these floats to floats of modified shape ⑤, part no. 861 181 as per amendment no. 37-01 and renew float bracket as required.

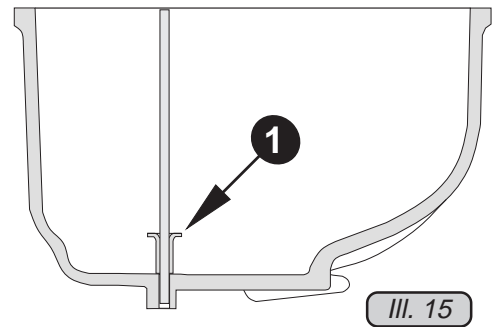

Ill. 15

Examine float valve with float chamber removed. At noticeable wear of beaded edge ③ at the sprung pin ④ the valve has to be renewed. If the distance becomes less than 0,5 mm (see ill. 17) the float level will be effected too.

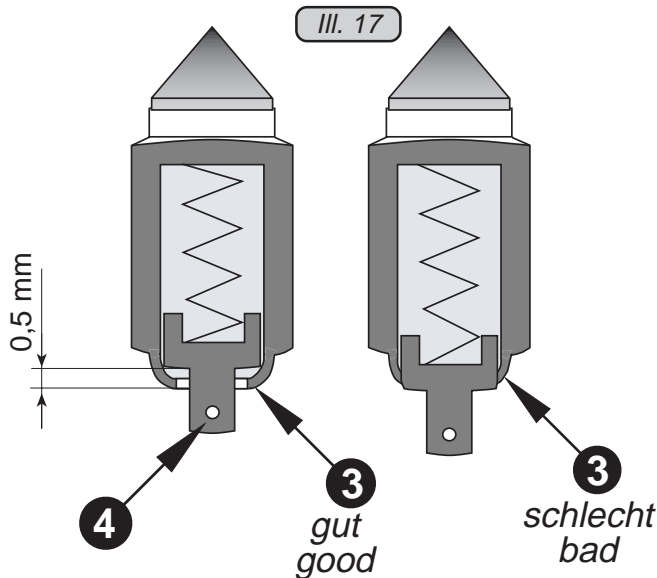

Ill. 17

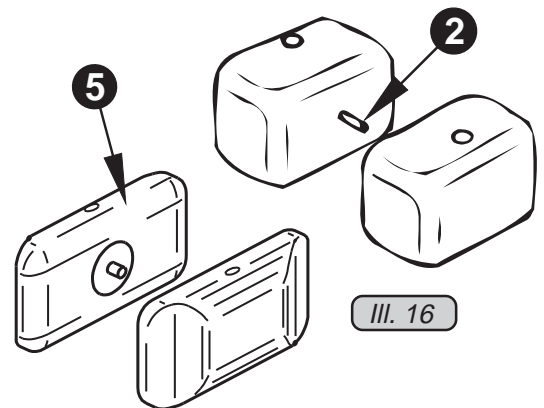

Ill. 16

7) Check of valve spring tension

■ **ATTENTION:** On engines from number 4,076.220 onwards this check is not required anymore and can be dropped therefore for this engine.

Disconnect minus terminal of the battery. Remove Allen screw ① M6x30 and washer ② from valve cover and take off cover along with O-rings ③ and ④.

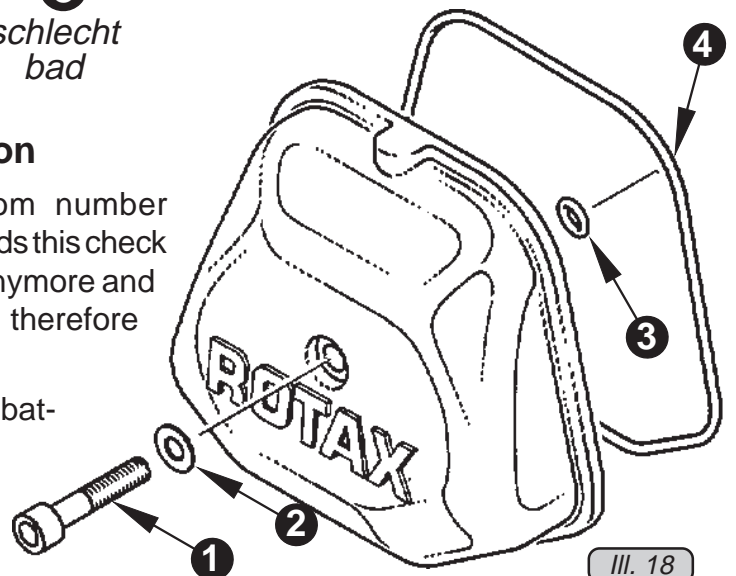

Ill. 18

