

**Engine type 912 A, Ignition unit with resistor spark plug**

part no. 897 681

**Matter:**

Introduction of a new resistor spark plug 12 mm DCPR7E, replacing the 12 mm EYQUEM spark plug AD800L with screw-connection ❶.

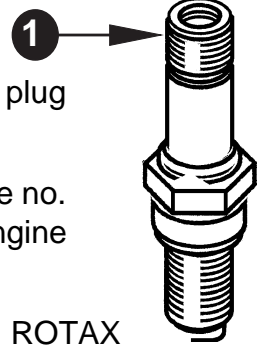

ill. 1

**Concerned:**

All motorglider engines of type 912 A, up to engine no. 4,076.006 for spare parts service. Beginning with engine no. 4,076.007 the new spark plug is fitted.

**Reason:**

The EYQUEM spark plug cannot be supplied by ROTAX any more.

**Urgency:**

as required

**Measures:**

**a) spare parts service**

- 1) Conversion of ignition unit to resistor spark plugs and resistor plug connectors, according to stated instructions.
- 2) Include amendment no. 3 into the Operator's Manual and proceed accordingly.
- 3) After conversion, carry out test run including check of ignition circuits according to chapter 5.3) in the Operator's Manual.
- 4) Entry of the changes in the log book with date of effectiveness and reference to this TB (Technical Bulletin).

**b) new engine:**

no actions, beginning with engine no. 4,076.007 resistor spark plug is fitted at ROTAX.

**Weight and**

**centre of gravity:**

not affected

**Remarks:**

- Amendment no. 3 of the Operator's Manual available at Bombardier-Rotax GmbH, Gunskirchen, Austria.
- Order parts as required per chapter 4 on the list of instructions for conversion, from the engine manufacturer.
- All work to be executed by an aircraft mechanic.

Gunskirchen, 1992 07 09

The technical content of this Service Bulletin has been approved by ACG.

**Instructions for conversion:**

**1) Conversion to resistor plug connectors and resistor spark plugs:**

Sever all H.V. leads by a neat cut direct beside the screw connection ②.

Prior to the skinning of insulation slide a 40 mm long shrinktube ③ part no. 860 621 far enough on to H.V. lead. Shorten the outer, blue sheathing ④ by 22 mm and the screening harness ⑤ by 18mm.

■ **ATTENTION:** Slide suitable tube under screening harness prior to shortening of harness, to protect insulation ⑦.

Place 30 mm long shrinktube ⑥ part no. 260 791 under screening harness ⑤ ending flush with cable and heat up evenly by hot air.

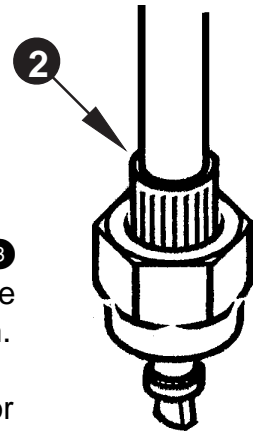

ill. 2

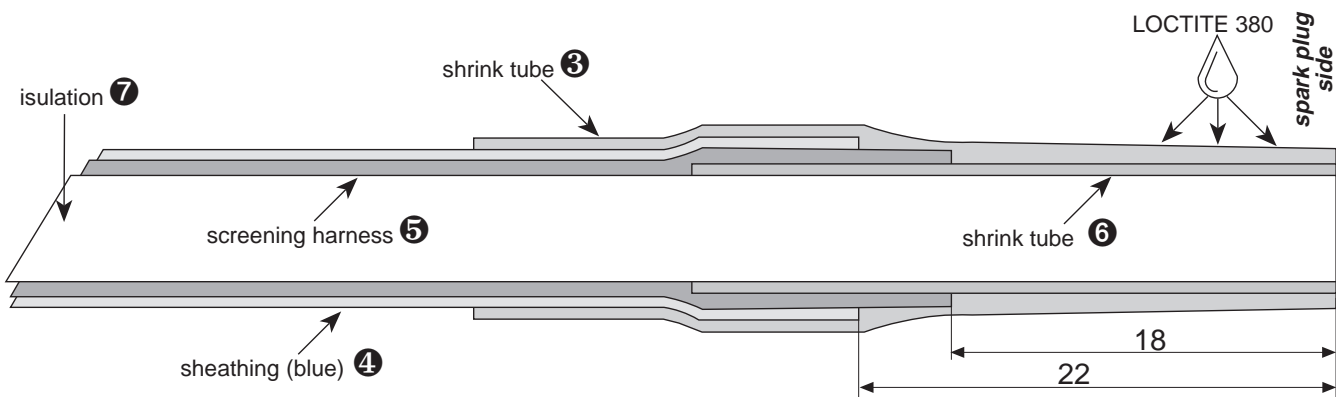

ill. 3

Flatten out screening harness ⑤, shift outer shrinktube ③ to end of cable and heat up evenly by hot air.

Apply LOCTITE 380 to the front end of H.V. lead and fit to resistor plug connector ⑧.

◆ **NOTE:** Resistor plug connector is furnished inside with a threaded prong!

Secure spark plug connector additionally by cable strap ⑨, part no. 866 710.

Repeat procedure on all eight H.V. leads.

■ **IMPORTANT:** Use only same type of connectors and spark plugs on one engine.

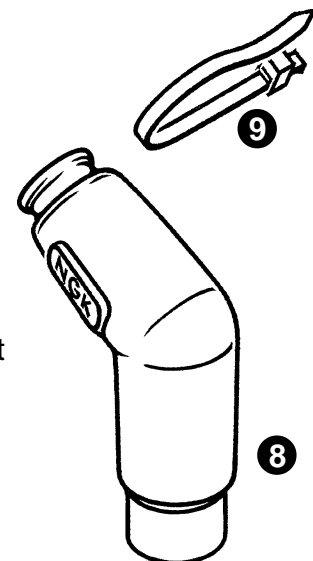

ill. 4

## 2) Conversion to resistor spark plug connectors, resistor spark plugs and simultaneous renewal of H.V. ignition leads

On the plug-side follow procedure as described in point 1).

At the ignition coil end, the skinning of the blue sheathing ① and of the screening harness ② to be carried out according to the following table and sketch. The skinning length differs due to the arrangement of the ignition coils.

■ **ATTENTION:** Never damage insulation ③ of the ignition leads. Use protection tube!

ignition H.V. lead	total length L2⑦	length L1⑧	sheathing length⑤
1 Top	840 mm	150 mm	130 mm
2 Top	790 mm	100 mm	80 mm
3 Top	790 mm	100 mm	80 mm
4 Top	840 mm	150 mm	130 mm
1 Bottom	860 mm	100 mm	80 mm
2 Bottom	860 mm	100 mm	80 mm
3 Bottom	910 mm	150 mm	130 mm
1 Bottom	860 mm	100 mm	80 mm

Place 20 mm long shrinktube ④ under screening harness and heat up evenly by hot air. Slide corresponding protection hose ⑤ on H.V. cable. Place 25 mm long shrink tube ⑥ 5 mm past cable end and heat up.

Connect each of the ignition H.V. cables to ignition coils according to following wiring diagram and hold cables in position by the clip plate on the screening box. The ignition cables 3B and 1T are tied together by a cable strap.

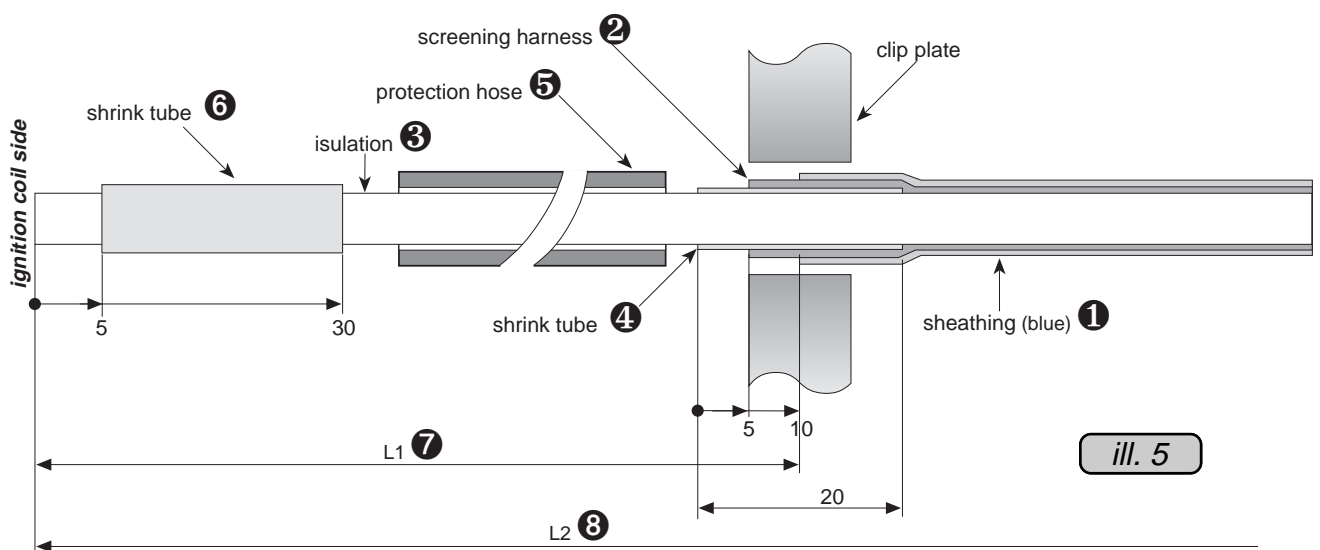

All eight plugs to be replaced by resistor spark plugs DCPR7E using plug spanner 16 A/F. Tighten to 20 Nm (177 in.lb.) on cold engine. Connections according to following wiring diagram.

**3) Wiring diagram for high voltage leads:**

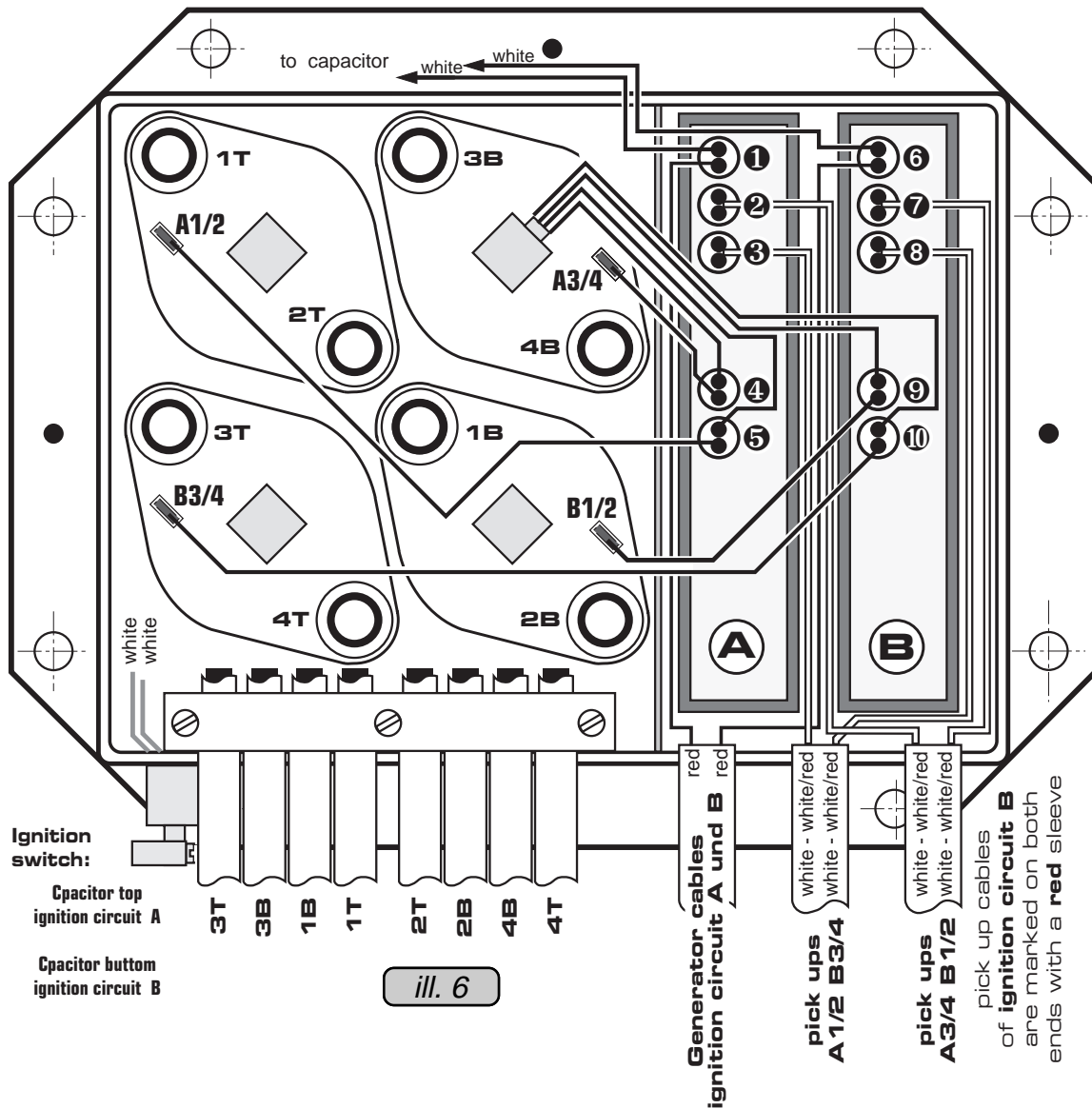

ill. 6

**4) Parts needed:**

for chapter 1)

1	Spark plug conversion kit	886 830
	consisting of:	
8	spark plug 12 DCPR7E	897 255
8	resistor plug connector ⑧ 5 kΩ	265 240
	VD05 FMH	
8	cable strap ⑨	866 710
8	shrink tube 40 mm ③	860 621
8	shrink tube 30 mm ⑥	260 791
1	plug spanner 16 A/F	276 282
1	LOCTITE 380	897 511

additional for chapter 2)

8	shrink tube 20 mm ④	260 793
8	shrink tube 25 mm ⑥	860 531
2	H.V. lead 990 mm	965 301
2	H.V. lead 1040 mm	965 302
3	H.V. lead 1060 mm	965 303
1	H.V. lead 1110 mm	965 304
1	cable strap	866 710